

Teknik Özellikler

TİPLER	Motor Gücü (HP)	Su Giriş/Çıkış (inç)*	M.T. Bağlantı (inç)**	Ağırlık (kg)	TİPLER	Motor Gücü (HP)	Su Giriş/Çıkış (inç)	M.T. Bağlantı (inç)**	Ağırlık (kg)	TİPLER	Motor Gücü (HP)	Su Giriş/Çıkış (inç)	M.T. Bağlantı (inç)**	Ağırlık (kg)
403/10-1	1	1"-1"	1"	37	403/10-2	1	2"-1 1/2"	1"	87	403/10-3	1	2 1/2"-2"	1"	102
403/15-1	1,5	1"-1"	1"	40	403/15-2	1,5	2"-1 1/2"	1"	92	403/15-3	1,5	2 1/2"-2"	1"	127
403/16-1	2	1"-1"	1"	44	403/16-2	2	2"-1 1/2"	1"	97	403/16-3	2	2 1/2"-2"	1"	113
406/11-1	2	1"-1"	1"	42	406/11-2	2	2"-1 1/2"	1"	81	406/11-3	2	2 1/2"-2"	1"	105
406/15-1	3	1"-1"	1"	50	406/15-2	3	2"-1 1/2"	1"	102	406/15-3	3	2 1/2"-2"	1"	162
406/18-1	4	1"-1"	1 1/2"	57	406/18-2	4	2"-1 1/2"	1 1/2"	110	406/18-3	4	2 1/2"-2"	1 1/2"	170
408/10-1	3	1 1/2"-1 1/2"	1 1/2"	40	408/10-2	3	2 1/2"-2"	1 1/2"	70	408/10-3	3	3"-2 1/2"	1 1/2"	100
408/14-1	4	1 1/2"-1 1/2"	1 1/2"	50	408/14-2	4	2 1/2"-2"	1 1/2"	79	408/14-3	4	3"-2 1/2"	1 1/2"	108
408/17-1	5,5	1 1/2"-1 1/2"	1 1/2"	65	408/17-2	5,5	2 1/2"-2"	1 1/2"	100	408/17-3	5,5	3"-2 1/2"	1 1/2"	135
610/8-1	4	1 1/2"-1 1/2"	1 1/2"	96	610/8-2	4	3"-2 1/2"	1 1/2"	135	610/8-3	4	4"-3"	1 1/2"	174
610/10-1	5,5	1 1/2"-1 1/2"	1 1/2"	107	610/10-2	5,5	3"-2 1/2"	1 1/2"	157	610/10-3	5,5	4"-3"	1 1/2"	207
610/12-1	7,5	1 1/2"-1 1/2"	1 1/2"	115	610/12-2	7,5	3"-2 1/2"	1 1/2"	171	610/12-3	7,5	4"-3"	1 1/2"	227
615/7-1	5,5	1 1/2"-1 1/2"	1 1/2"	105	615/7-2	5,5	3"-2 1/2"	1 1/2"	155	615/7-3	5,5	4"-3"	1 1/2"	205
615/9-1	7,5	1 1/2"-1 1/2"	1 1/2"	113	615/9-2	7,5	3"-2 1/2"	1 1/2"	169	615/9-3	7,5	4"-3"	1 1/2"	225
615/10-1	10	1 1/2"-1 1/2"	1 1/2"	120	615/10-2	10	3"-2 1/2"	1 1/2"	182	615/10-3	10	4"-3"	1 1/2"	244
620/7-1	7,5	2"-2"	2"	111	620/7-2	7,5	4"-3"	2"	175	620/7-3	7,5	5"-4"	2"	239
620/8-1	10	2"-2"	2"	118	620/8-2	10	4"-3"	2"	183	620/8-3	10	5"-4"	2"	248
620/9-1	10	2"-2"	2"	119	620/9-2	10	4"-3"	2"	185	620/9-3	10	5"-4"	2"	251
631/6-1	15	2"-2"	2"	139	631/6-2	15	4"-3"	2"	225	631/6-3	15	5"-4"	2"	311
631/7-1	15	2"-2"	2"	140	631/7-2	15	4"-3"	2"	227	631/7-3	15	5"-4"	2"	314
631/8-1	15	2"-2"	2"	141	631/8-2	15	4"-3"	2"	229	631/8-3	15	5"-4"	2"	317

Not: Boru çapları galvaniz boruya göre verilmiştir. Plastik boruların iç çapları, galvanize göre dardır. Plastik boru kullanılacaksa, galvaniz borunun iç çapını sağlayan boyut kullanılmalıdır.

(*) Pompa üzerindeki su giriş ve su çıkış çapları eşittir. Fakat emiş tesisatı bir boy büyük olarak çekilmelidir. Örneğin; 2" giriş ise emiş tesisatı 2,5" olacak gibi.

(**) MT-Membranlı basınç dengeleme tankı.

ALD 400 Serisi Pompa Eğrileri



Genel Eğriler

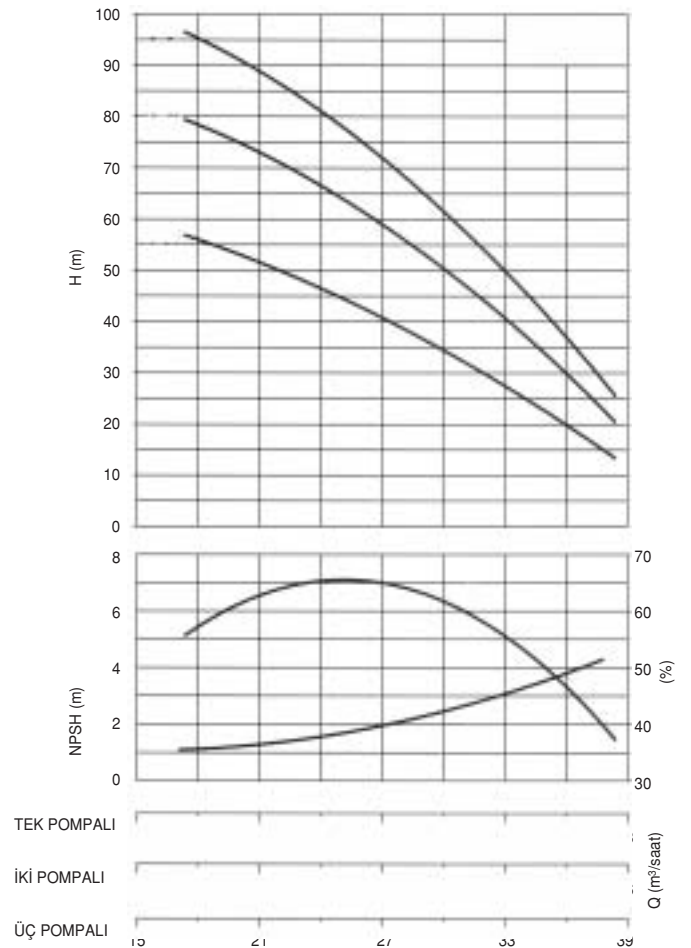
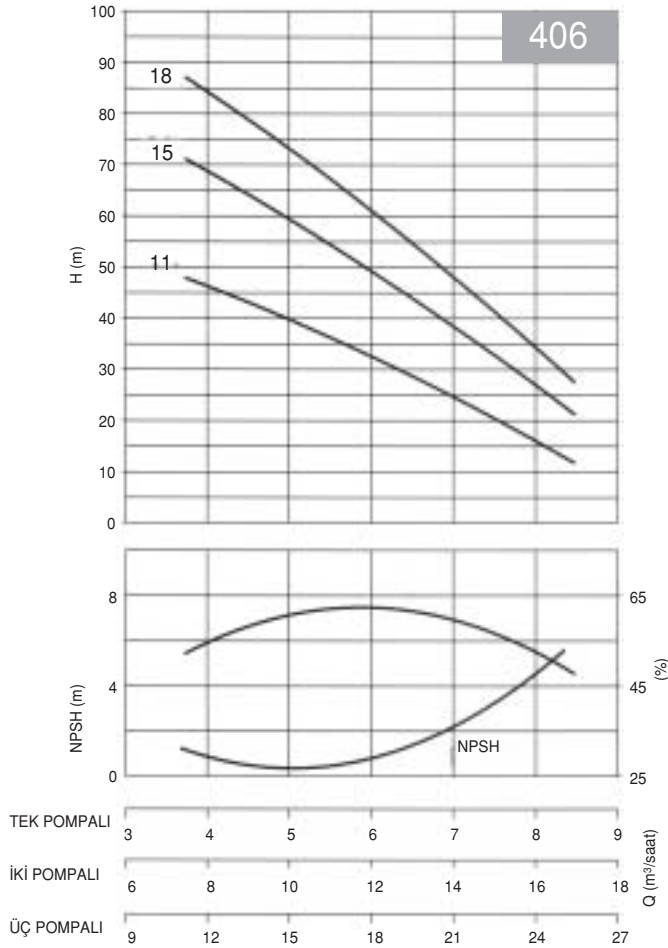
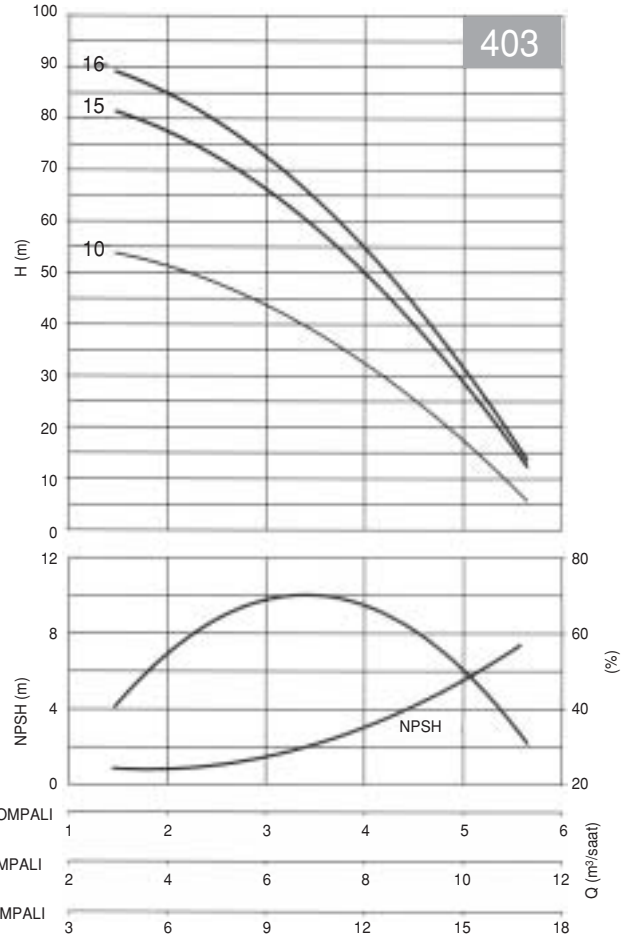
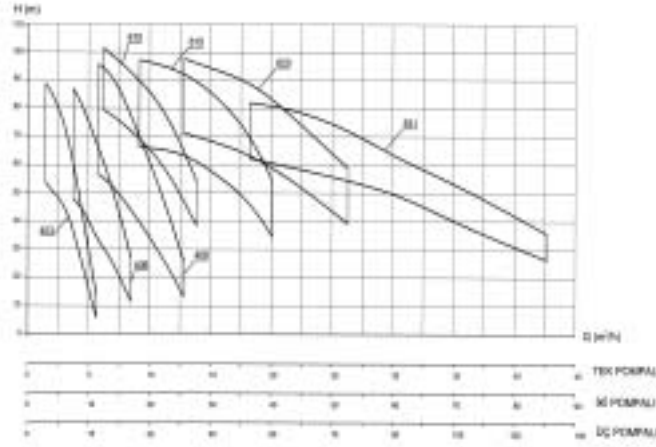

ALD 600 Serisi Pompa Eğrileri

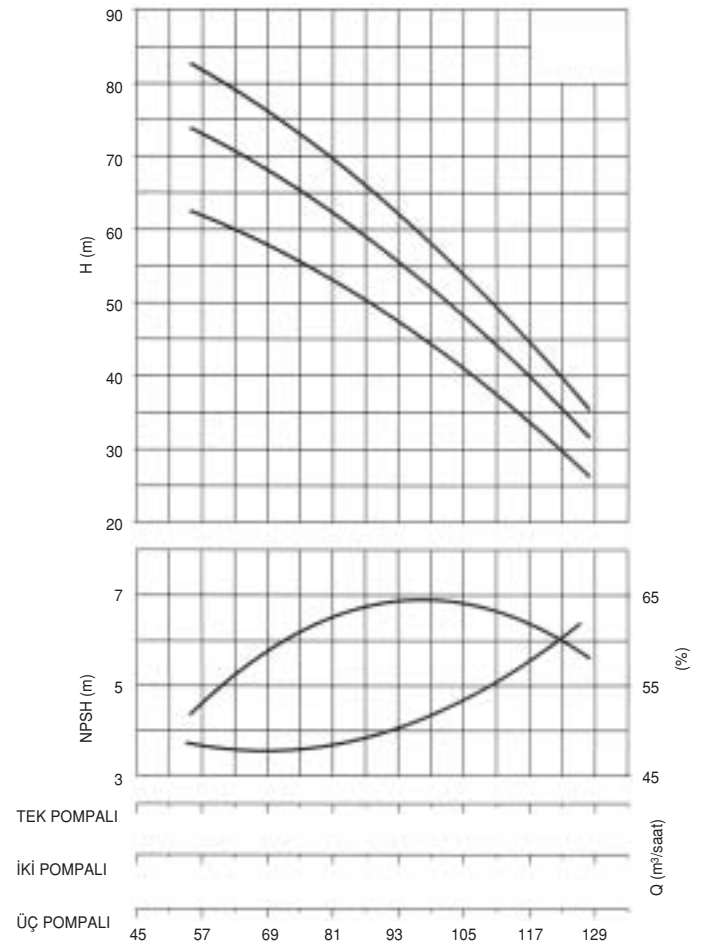
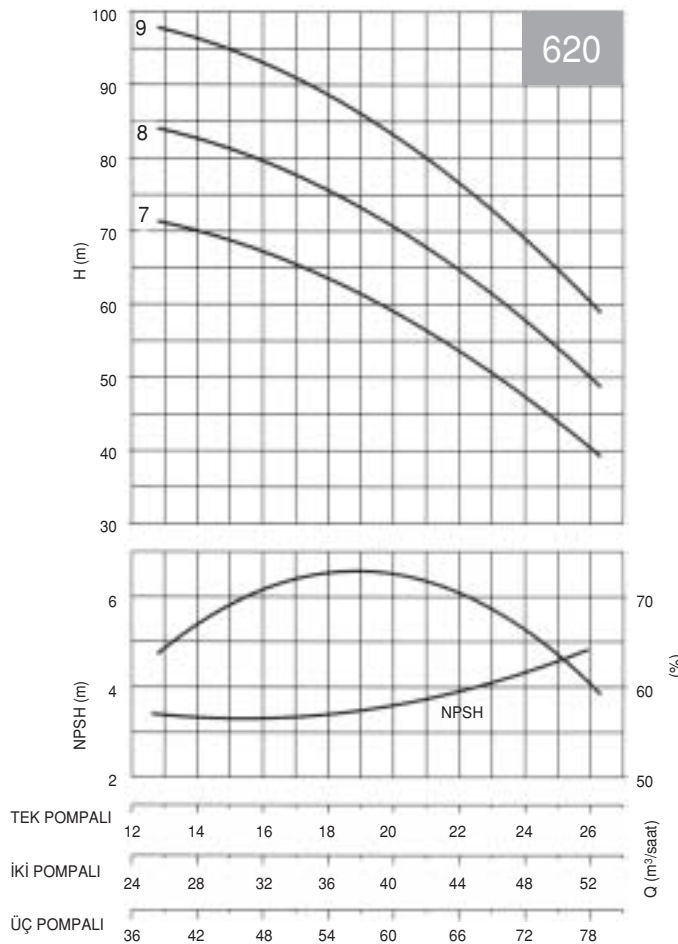
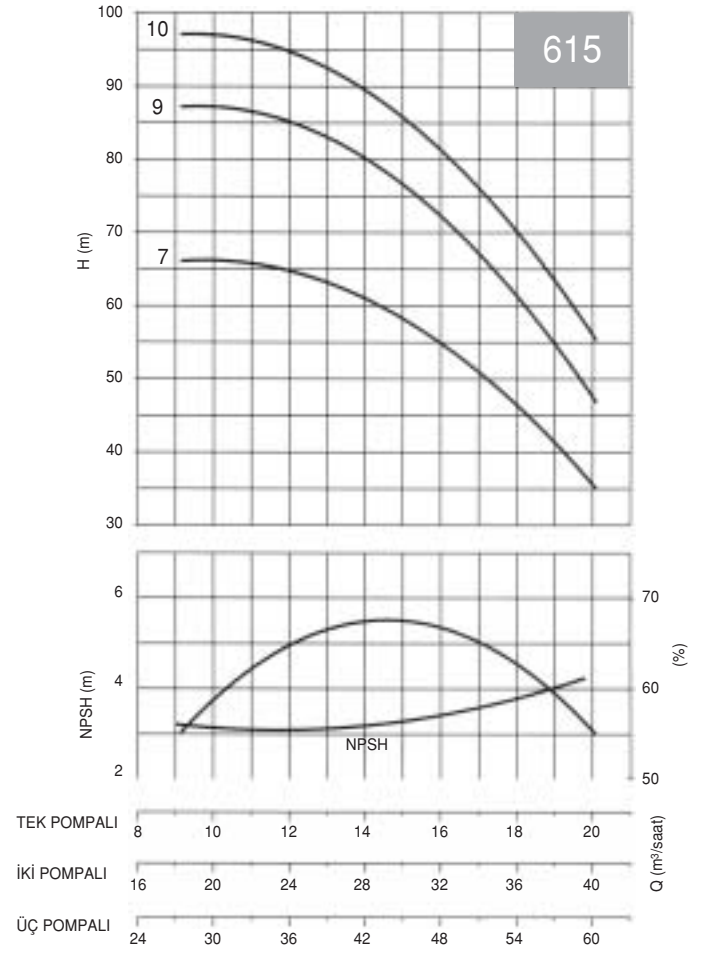
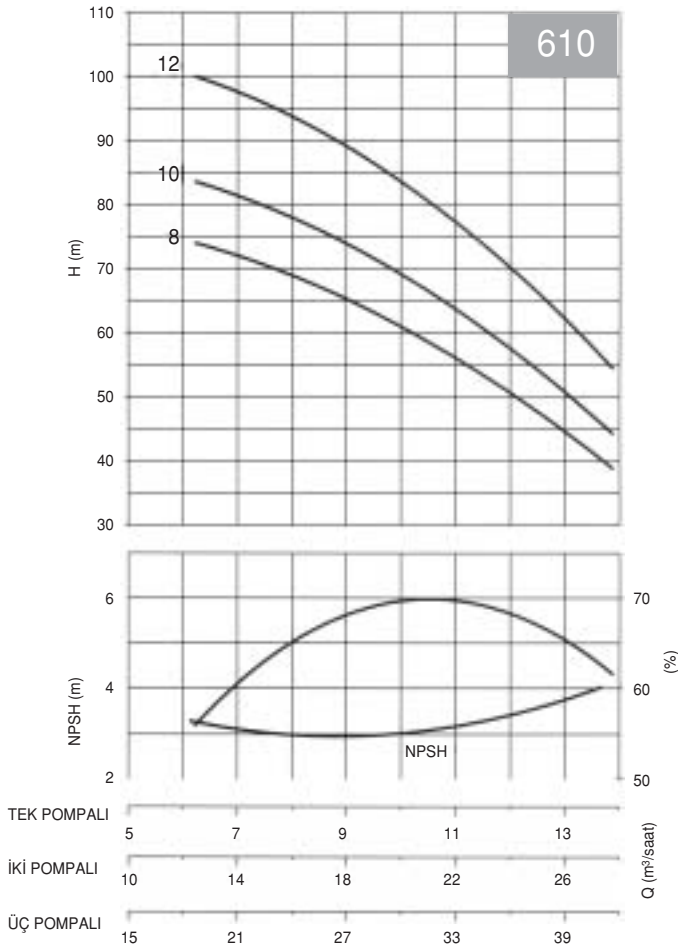

Boyutlar

TEK POMPALI HİDROFORLAR

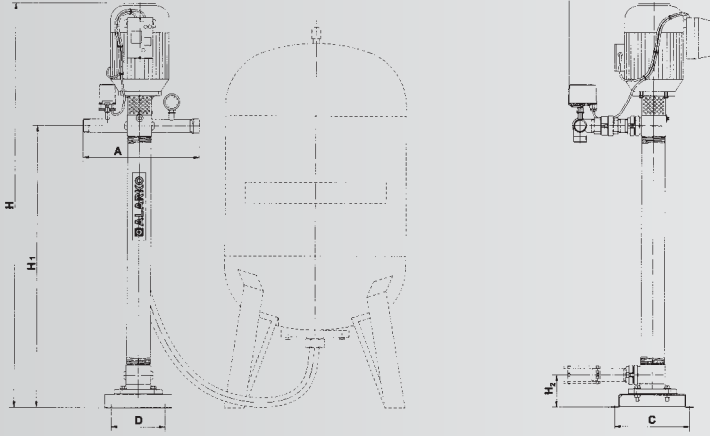

TİPLER	A	B	C	D	H	H1	H2
403/10-1	434	477	278	200	939	578	121
403/15-1	434	477	278	200	1089	728	121
403/16-1	434	487	278	200	1136	758	121
406/11-1	434	487	278	200	1129	751	121
406/15-1	434	487	278	200	1326	923	121
406/18-1	434	496	278	200	1485	1052	121
408/10-1	434	512	278	200	1131	728	121
408/14-1	434	521	278	200	1341	908	121
408/17-1	434	533	278	200	1495	1043	121
610/8-1	514	553	308	250	1105	629	125.5
610/10-1	514	565	308	250	1214	719	125.5
610/12-1	514	585	308	250	1355	809	125.5
615/7-1	514	565	308	250	1128	633	125.5
615/9-1	514	585	308	250	1273	727	125.5
615/10-1	514	678	308	250	1320	774	125.5
620/7-1	516	592	308	250	1227	681	125.5
620/8-1	516	687	308	250	1280	734	125.5
620/9-1	516	687	308	250	1333	787	125.5
631/6-1	516	687	308	250	1281	697	125.5
631/7-1	516	687	308	250	1343	759	125.5
631/8-1	516	687	308	250	1405	821	125.5

İKİ POMPALI HİDROFORLAR

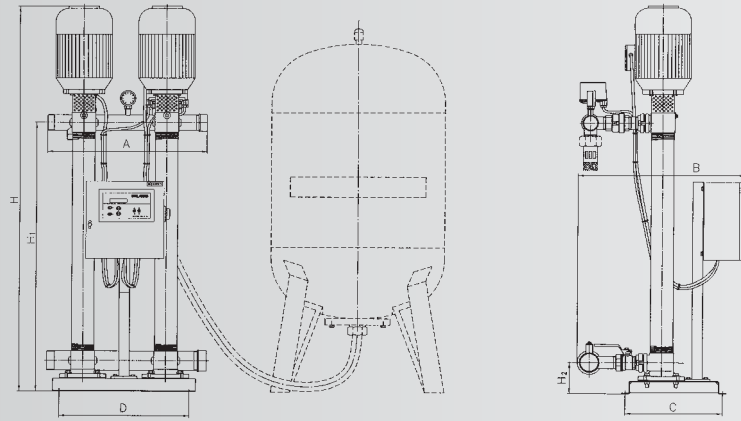

TİPLER	A	B	C	D	H	H1	H2
403/10-2	616	633	378	502	939	578	121
403/15-2	616	633	378	502	1089	728	121
403/16-2	616	633	378	502	1136	758	121
406/11-2	616	633	378	502	1129	751	121
406/15-2	616	633	378	502	1326	923	121
406/18-2	616	633	378	502	1485	1052	121
408/10-2	617	669	378	502	1131	728	121
408/14-2	617	669	378	502	1341	908	121
408/17-2	617	669	378	502	1495	1043	121
610/8-2	717	738	408	650	1105	629	125.5
610/10-2	717	738	408	650	1214	719	125.5
610/12-2	717	738	408	650	1355	809	125.5
615/7-2	717	738	408	650	1128	633	125.5
615/9-2	717	738	408	650	1273	727	125.5
615/10-2	717	738	408	650	1320	774	125.5
620/7-2	719	761	408	650	1227	681	125.5
620/8-2	719	761	408	650	1280	734	125.5
620/9-2	719	761	408	650	1333	787	125.5
631/6-2	719	761	408	650	1281	697	125.5
631/7-2	719	761	408	650	1343	759	125.5
631/8-2	719	761	408	650	1405	821	125.5

ÜÇ POMPALI HİDROFORLAR

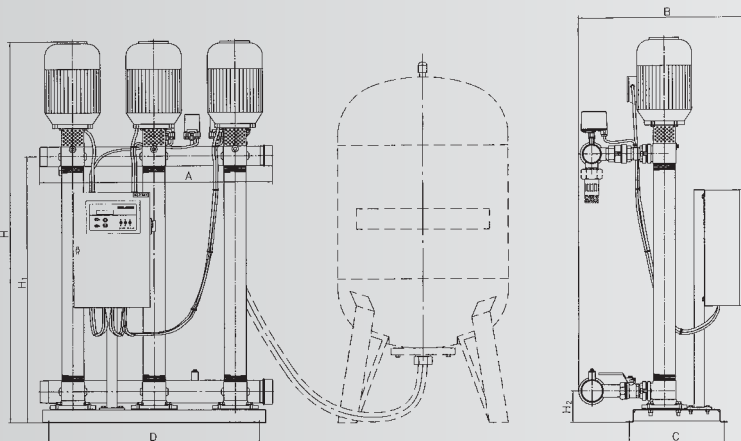

TİPLER	A	B	C	D	H	H1	H2
403/10-3	917	650	378	830	939	578	121
403/15-3	917	650	378	830	1089	728	121
403/16-3	917	650	378	830	1136	758	121
406/11-3	917	650	378	830	1129	751	121
406/15-3	917	650	378	830	1326	923	121
406/18-3	917	650	378	830	1485	1052	121
408/10-3	917	683	378	830	1131	728	121
408/14-3	917	683	378	830	1341	908	121
408/17-3	917	683	378	830	1495	1043	121
610/8-3	1119	768	408	1050	1105	629	125.5
610/10-3	1119	768	408	1050	1214	719	125.5
610/12-3	1119	768	408	1050	1355	809	125.5
615/7-3	1119	768	408	1050	1128	633	125.5
615/9-3	1119	768	408	1050	1273	727	125.5
615/10-3	1119	750	408	1050	1320	774	125.5
620/7-3	1119	803	408	1050	1227	681	125.5
620/8-3	1119	785	408	1050	1280	734	125.5
620/9-3	1119	785	408	1050	1333	787	125.5
631/6-3	1119	785	408	1050	1281	697	125.5
631/7-3	1119	785	408	1050	1343	759	125.5
631/8-3	1119	785	408	1050	1405	821	125.5

Tüm ölçüler mm'dir.